



PNEUMATIC CONVEYING SYSTEMS

BULK BAG UNLOADER



OVERVIEW

Cyclonaire's quality built bulk bag unloading station is the most flexible and most customizable choice for your demanding needs and cost conscious budget.

Start with our basic heavy duty, carbon steel box tubing frame, custom built to handle any weight or size of bulk bags. Add custom features for your needs—electric hoist, bag tensioners, bag massaging paddles, load cells or glove box—plus more.

Get the economy of bulk bag supply with the safety, convenience and affordability of Cyclonaire bulk bag unloaders.

Quality, custom built at competitive prices.

APPLICATIONS

- Any process requiring unloading/handling of bulk bags
- Option uses: weigh/batching via loss-in-weight, integrated conveying from point of discharge

MATERIALS / CHARACTERISTICS

- Any free flowing dry material in bulk bags

CAPACITY

- Custom built to accommodate your unloading needs

BENEFITS AND FEATURES

- Supports and seals any size or style bulk bag for discharge
- Unload without bag slippage, material dusting or spillage
- Safe, heavy-duty welded and bolted tubular steel frame
- Standard:
 - Carbon steel, welded and bolted tubular frame
- Specify:
 - Stainless steel
 - Piercing blade
 - Electric hoist or manual lift
 - Load cell for weigh/batching
 - Support trays and/or bag tensioners
 - Iris valve or pinch bars to meter flow
 - Bag massagers to assist discharge
 - Dust tight glow box hopper or access hopper
 - Integral dust suppression/collection

REQUIREMENTS

- 110 VAC, 50-60 Hz if electric hoist is chosen
- 90-100 PSIG @ 3-5 SCFM for dust control

BULK BAG UNLOADING STATION

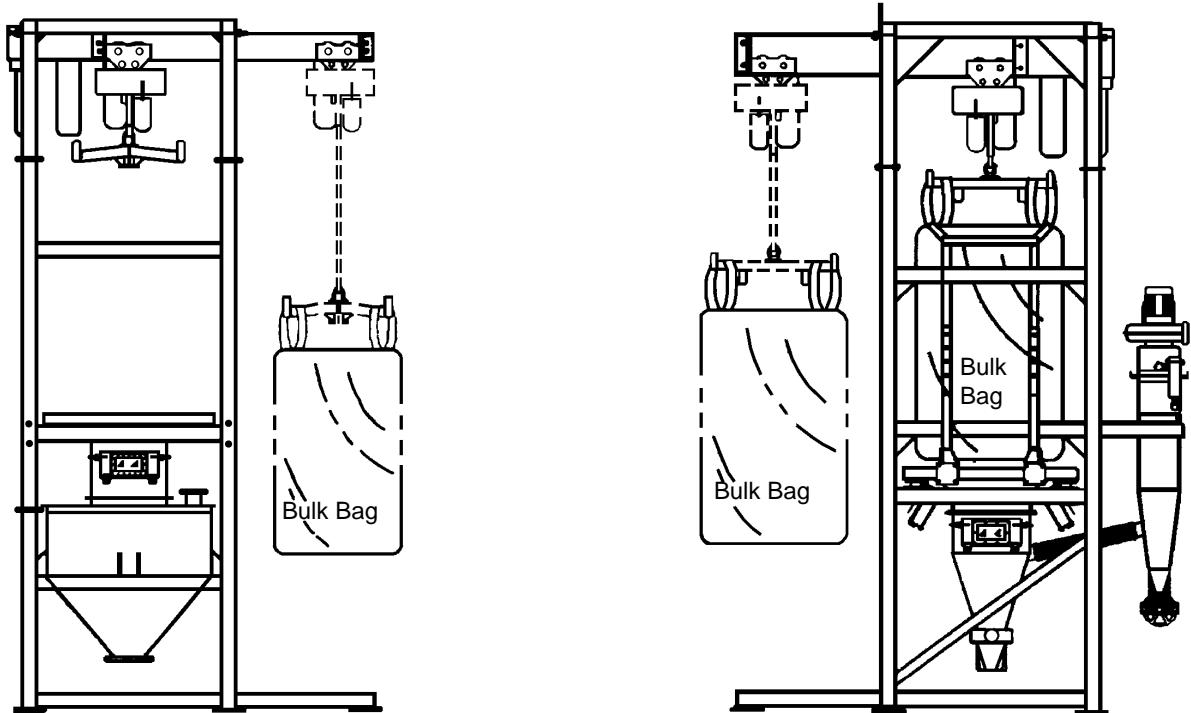

Standard Features:

- Carbon steel 2 ton frame and hopper tray
- Forklift-load capability
- Welded and bolted construction

Optional features:

- 304 Stainless Steel on material contact points
- Epoxy coated material contact points
- Manual, pneumatic or electric hoist
- Push or motorized trolley
- NEMA 7/9 controls
- Pneumatic bag massager system
- Glove box w/hand holes
- Discharge chute w/access door
- Dust collection/suppression system
- Integral hopper for material storage

