



PNEUMATIC CONVEYING SYSTEMS

HC Series CONVEYOR



OVERVIEW

The HC Series is a high capacity, side inlet, vacuum loaded, semi-dense phase conveyor with a capacity to 80+ TPH. It is best suited for powdered materials that are abrasive or fluidizable.

Medium pressure blower air is used to venturi-vacuum load and pressure convey air at intermediate line velocities and material-to-air ratios for less abrasive wear and particle degradation. Integral dust separation is included.

The unit is capable of multiple applications, from bulk carrier, IBC and bulk bag unloading to in-plant transfer. With optional load cells, the HC Series can also weigh and batch with inventory control.

APPLICATIONS

- High capacity transfers with vacuum loading
- Bulk carrier, IBC and bulk bag unloading/In-plant transfer
- Side inlet vacuum loading for restricted headroom

MATERIALS / CHARACTERISTICS

- Fluidizable materials that are abrasive

CAPACITY

- Up to 80+ TPH

BENEFITS AND FEATURES

- Semi-dense conveyor uses medium pressure blower air to convey material at intermediate line velocities (<2000-3000 fpm) and high material-to-air ratios (50-20) for low abrasion
- No costly pits required
- Integral dust separation for reduced venturi wear
- Less operator supervision via automated controls
- Specify:
 - Carbon steel, stainless steel or epoxy coated
 - Load cells
 - Portable or stationary
 - Multiple inlets
 - Butterfly outlet valve

REQUIREMENTS

- 110 VAC, 50-60 Hz, 12 VDC
- 15 PSIG convey air, 90-100 PSIG control air @ 3-5 SCFM

HC CONVEYOR

LOAD CYCLE

As the load cycle begins, the suction valve opens while the inlet and discharge flap valves are closed. The air pressure generates a vacuum by patented venturi action. As the vacuum increases in the transfer vessel, the inlet valve opens. Pulled by suction of up to 15 inches of mercury, the material flows from the source into the transfer vessel. The electronic level control regulates filling of the transfer vessel to optimum levels during the load cycle. However, a back-up solid-state timer takes over operation in the event material flow is interrupted.

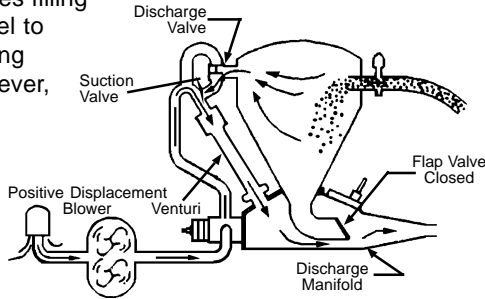

DISCHARGE CYCLE

When the transfer has been filled to the optimum level, the inlet and suction valves close and the discharge valve opens. The same positive air supply which created the vacuum is used to push the material into the discharge manifold where it is fluidized for semi-dense conveying—thus minimizing particle degradation, reducing line wear and increasing system efficiency.

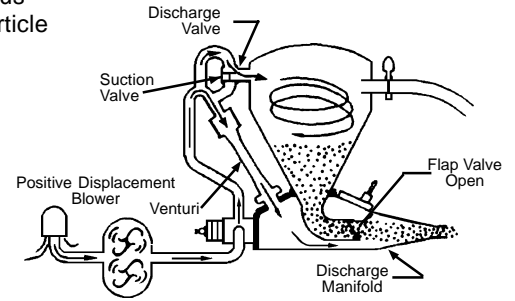

PRODUCT SPECIFICATIONS

MODEL NUMBER	VOLUME CU.FT.	A	B	C	D	AIR INLET	MATERIAL INLET	DISCHARGE	APPROX. WEIGHT
HC-10	10	30	80	36	6	5	5	5	1200
HC-20	15	33	86	36	6	5	5	5	1350
HC-30	30	42	100	36	6	5	5	5	1400
HC-50	50	60	125	38	7	6	6	6	1650
HC-75	75	60	135	42	7	6	8	8	1800
HC-100	100	72	150	40	10	6	8	8	2150
HC-150	150	72	161	40	10	6	8	8	3450

NOTE: Dimensional data for reference only. Subject to change without notice. All weights are in pounds, all dimensional units are in inches, unless noted. Air inlet, material inlet, and discharge may vary per application. Series with connection type dimensions based on MNPT outlet.

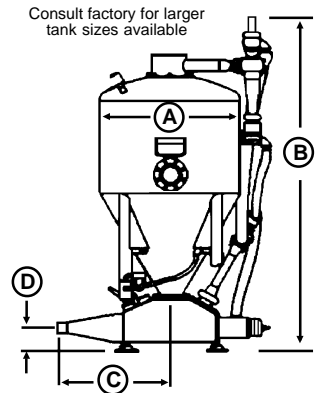

SEMI-DENSE PHASE TRANSFER

