

CYCLONAIRE CEMENT INDUSTRY

Standard System Pricing Guide

GF Series Solution

		Pipe Diameter		
		8"	10"	12"
Total Distance (Allow 20ft per elbow)	100ft	99	--	--
	150ft	76	106	--
	200ft	62	93	106
	300ft	45	69	96

STPH [standard tons per hour]

HC-150 HC-200

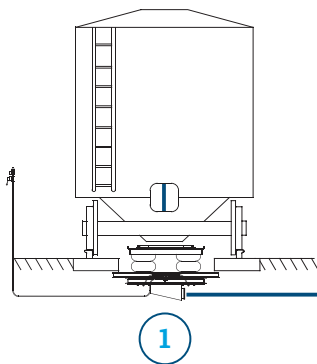

Equipment List

- (2) Cyclolift
- (1) Filter Receiver
- (1) GF Series Conveyor
- (1) Vacuum Pump & Filter
- (1) Blower Package
- (1) Silo Bin Vent
- (1) Control System

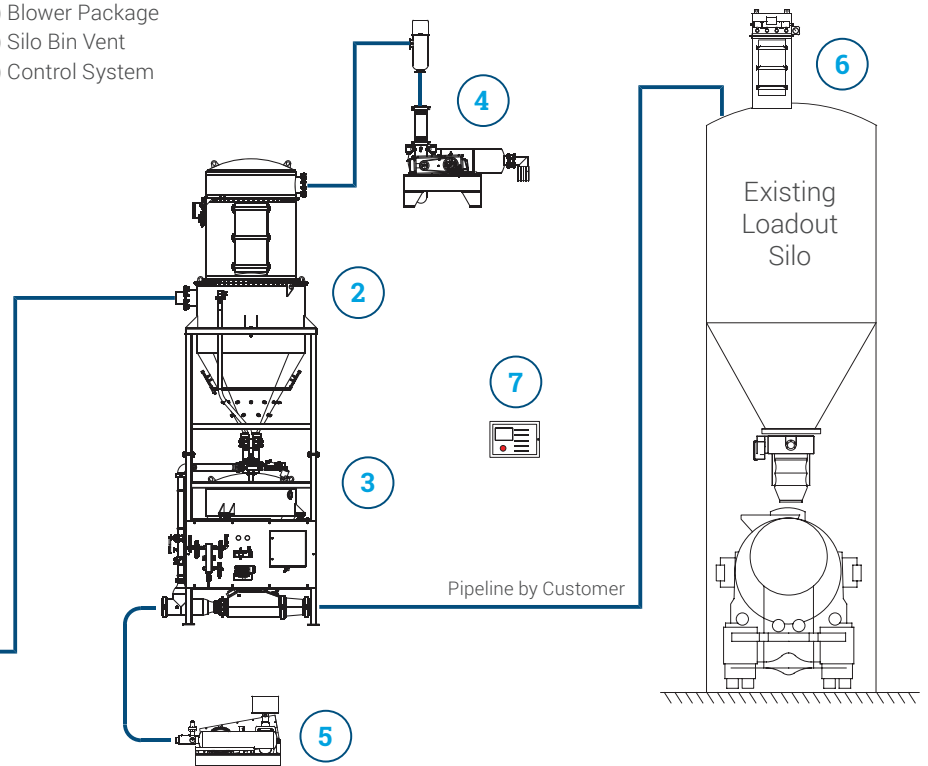

Convey Line Size	8"	10"	12"
Railcar Connection	(2) Cyclolift w/ Railpan and Air Inlet Assembly	(2) Cyclolift w/ Railpan and Air Inlet Assembly	(2) Cyclolift w/ Railpan and Air Inlet Assembly
Vacuum Receiver	36-FR-42 w/ 200ft ³ Hopper	36-FR-42 w/ 250ft ³ Hopper	36-FR-42 w/ 250ft ³ Hopper
Vacuum Pump	2300 ICFM	2300 ICFM	2300 ICFM
	100 HP/12" Hg	100 HP/12" Hg	100 HP/12" Hg
GF	GF-150	GF-200	GF-200
Blower	1300 SCFM	2050 SCFM	3300 SCFM
	125 HP/15 psig	200 HP/15 psig	300 HP/15 psig
Bin Vent	36-DC-25	36-DC-49	36-DC-64
PLC	PLC Controller with HMI	PLC Controller with HMI	PLC Controller with HMI
TOTAL	\$279,000	\$327,000	\$375,000