

Dense Phase Gravity Loaded Conveyors

For transferring powdered, granular or pelletized products, nothing compares to the productivity of Cyclonaire's dense phase gravity-loaded bottom discharge conveyors (DPG-B). Using high-pressure air to achieve high material-to-air ratios, DPG-Bs minimize degradation and abrasive wear.

Go with a Dense Phase Conveyor That's Up to the Challenge

A Tough Industry Demands Tough Equipment — Gravity-loaded, bottom discharge transfer with 400+ TPH capacity makes light work of heavy loads.

Less Degradation — High material-to-air ratio and low line velocities help maintain material integrity.

Distance is No Problem — DPG-B conveyors successfully transfer materials over long distances.

Standard

Carbon Steel Construction; 24 VDC Instrumentation; High and Low Level Probe; Protective Dual Butterfly Inlet; Dual Setpoint Pressure Switch on Tank; Supply and Tank Pressure Gauge; Injector Air Supply Valve; Silicone VibraPads; Cyclonaire Blue Paint

Standard Options

304 Stainless Steel Material Contact; Cyclonaire White Paint; Pressure Transmitters; Numerous Inlet and Vent Valve Options; Source Aeration; Neoprene VibraPads; Configurable for Load Cell Weighing

Custom Options

High Temp Paint and Devices; Custom Colors/Coatings Available; 316/316L Stainless Steel Material Contact

Requirements:

- 90 PSIG Air (usage ranges by size)
- Power source

Technical Data

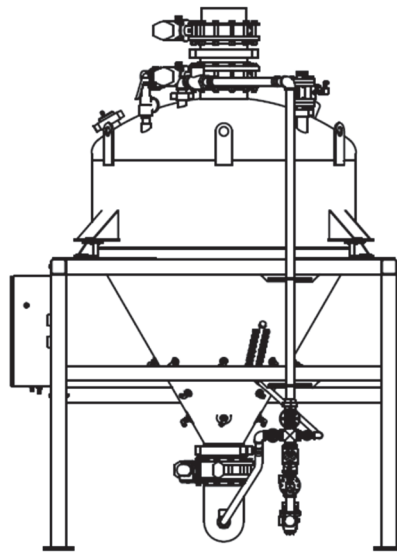
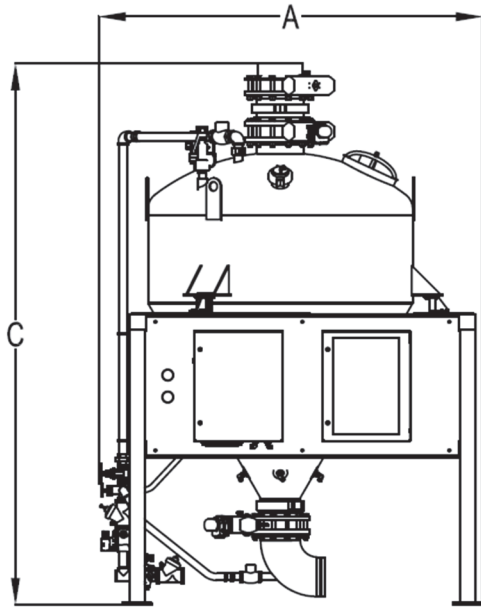
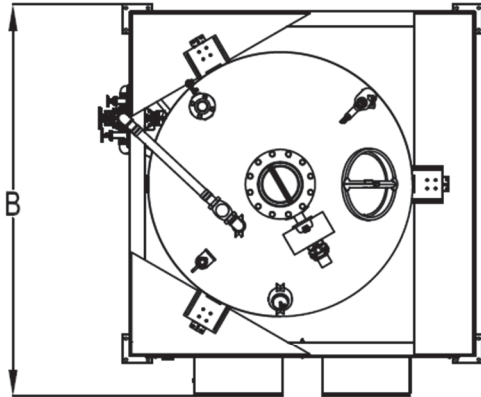

	Tank Volume	Tank Diameter	A	B	C	Approx. Weight Empty	Support Style
Model	[ft ³]	[in]	[in]	[in]	[in]	[lbs]	
DPG-1B	1	18	44	24	50	550	Legged
DPG-3B	3	24	44	37	55	700	Legged
DPG-5B	5	24	44	43	70	1015	Legged
DPG-10B	10	30	62	62	88	2150	Frame
DPG-15B	15	36	78	65	91	2300	Frame
DPG-25B	25	36	80	70	109	3000	Frame
DPG-50B	50	48	80	70	125	3360	Frame
DPG-75B	75	60	83	83	146	4300	Frame
DPG-100B	100	60	105	107	148	4400	Frame
DPG-150B	150	72				Contact Factory	Frame
DPG-200B	200	72				Contact Factory	Frame

Dimensions and weights are subject to change without notice

Tanks are built to ASME VIII Pressure Vessel codes

Weight estimates are of EMPTY conveyor

Contact sales@cyclonaire.com

cyclonaire
pneumatic conveying solutions

(800) 445-0730 | cyclonaire.com